

## ● Features

- I Aluminum crust surface with good performance in heat radiation, suitable for cooling plate installation, can be used in the atrocious environment.
- II Small size, high power load.
- III High insulating capacity, encapsulation by non-flame inorganic material, good performance in vibration.
- IV Multi connection form will be easy to fix.
- V Widely used in power supply, Transducer, Elevator, Arena audio and high requirement equipment industry.
- VI Resistance tolerance:  $\pm 1\%$ ,  $\pm 2\%$ ,  $\pm 5\%$ ,  $\pm 10\%$ .

## ● Dimensions

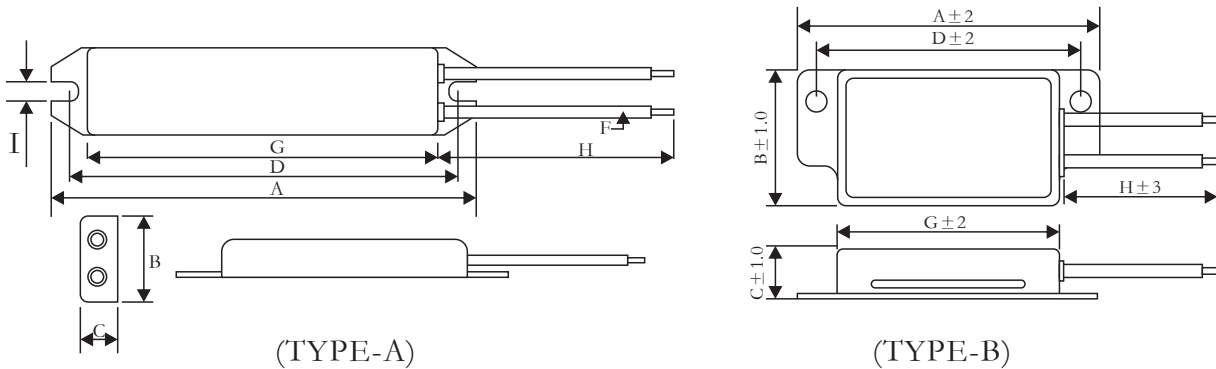

Type	Power (W)	Dimensions(mm)							
		A ± 2	B ± 1	C ± 1	D ± 2	G ± 2	F	H	I ± 0.5
MRY	40	80	36	13	70	60	0.75mm <sup>2</sup>	300	5
MRY	50	100	30	13	90	75	0.75mm <sup>2</sup>	300	5
MRY	60	100	30	13	90	75	0.75mm <sup>2</sup>	300	5
MRY	80	150	35	21	140	125	0.75mm <sup>2</sup>	300	6
MRY	100	130	42	21	118	108	0.75mm <sup>2</sup>	300	6
MRY	120	182	42	21	165	156	0.75mm <sup>2</sup>	300	6
MRY	150	182	42	21	165	156	0.75mm <sup>2</sup>	300	6
MRY	200	182	42	21	165	156	0.75mm <sup>2</sup>	300	6
MRY	300	230	42	21	210	200	0.75mm <sup>2</sup>	300	6

## ● Ordering Information

Example:

MRY	200	J	10R0	A
(1)	(2)	(3)	(4)	(5)
Series Name	Power Rating	Resistance Tolerance	Resistance	TYPE

(1) Type: MRY SERIES

(2) Power Rating: 40=40W, 60=60W, 100=100W, 200=200W

(3) Tolerance: F=  $\pm 1\%$ , G=  $\pm 2\%$ , J=  $\pm 5\%$ , K=  $\pm 10\%$

(4) Resistance Value: R100=0.1, 1R00=1, 10R0=10, 1000=100R, 1001=1K

(5) TYPE: A/B

## ● Reference Standards

JISC 5201-1

## Applications And Ratings

Rated Power(W)	Resistance Range( $\Omega$ )	Tolerance	T.C.R	Max Working Voltage	Max Overload Voltage	Dielectric Withstanding Voltage
40	1 $\Omega$ ~100K $\Omega$	F $\pm$ 1% G $\pm$ 2% J $\pm$ 5% K $\pm$ 10%	$\pm$ 300PPM/ $^{\circ}$ C	1000V	2000V	1500V/Ac
50	1 $\Omega$ ~100K $\Omega$					
60	1 $\Omega$ ~100K $\Omega$					
80	1 $\Omega$ ~100K $\Omega$					
100	1 $\Omega$ ~100K $\Omega$					
120	1 $\Omega$ ~100K $\Omega$					
150	1 $\Omega$ ~100K $\Omega$					
200	1 $\Omega$ ~100K $\Omega$					
300	1 $\Omega$ ~100K $\Omega$					

## Derating Curve

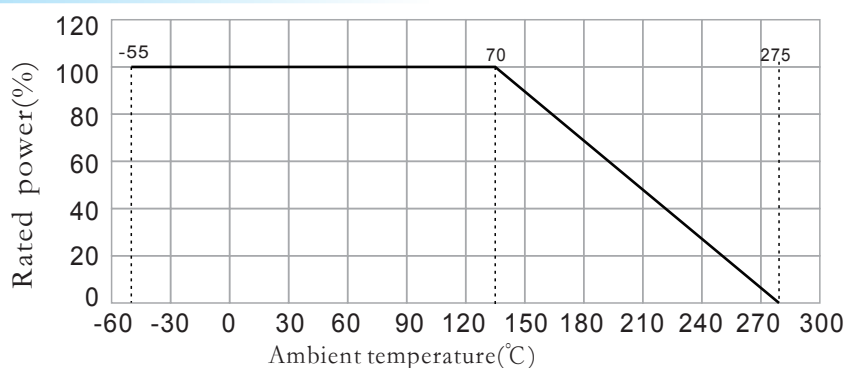

## Performance

Test Items	Performance	Test Methods(JIS C 5201-1)
Temperature coefficient	$\pm$ 300ppm/ $^{\circ}$ C	Test resistance value at normal temperature and normal temperature added 100 $^{\circ}$ C, calculate $^{\circ}$ C resistance value change rate.
Short time overload	$\Delta R \leq \pm (2\%R0 + 0.05\Omega)$	10X rated power or Max. overload voltage(get the lower) for 5seconds.
Resistance to soldering heat	$\Delta R \leq \pm (1\%R0 + 0.05\Omega)$	Immerge into the 350 $\pm$ 10 $^{\circ}$ C tin stove for 2~3 seconds
Dielectric withstanding voltage	No obvious mechanical damage or spark-over	Add AC 1500V or 2000V or 2500V for 1min.
Temperature cycle	$\Delta R \leq \pm (1\%R0 + 0.05\Omega)$	At -55 $^{\circ}$ C for 30min, then at +25 $^{\circ}$ C for 10~15min, then at +125 $^{\circ}$ C for 30min, then at +25 $^{\circ}$ C for 10~5 min, total 5cycles.
Load life in humidity	$\Delta R \leq \pm (3\%R0 + 0.05\Omega)$	Overload rated voltage or Max.working voltage(get the lower)for 1000hours (1.5hours on and half-hour off) at the 40 $\pm$ 2 $^{\circ}$ C and 90~95% relative humidity.
Load life in heat	$\Delta R \leq \pm (3\%R0 + 0.05\Omega)$	Overload rated voltage or Max.working voltage(get the lower)for 1000hours (1.5hours on and half-hour off) at the 70 $\pm$ 2 $^{\circ}$ C.
Terminal strength	$\Delta R \leq \pm (2\%R0 + 0.1\Omega)$	Pull:100N
Vibration	$\Delta R \leq \pm (2\%R0 + 0.1\Omega)$	Frequency:10~55Hz, Swing:0.75mm, Test time:6hours
Nonflammability	No visible flame	Respectively load AC voltage by 5,10,16 times rated power for 5 minutes.