



● Features

- Low resistance value that withstand high current
- Compatible with automotive part
- Customized product
- Stable performance and perfect reliability

● Applications

- Current Sensing
- Feedback
- Low Inductance
- Surge And Pulse

● Dimensions And Rating

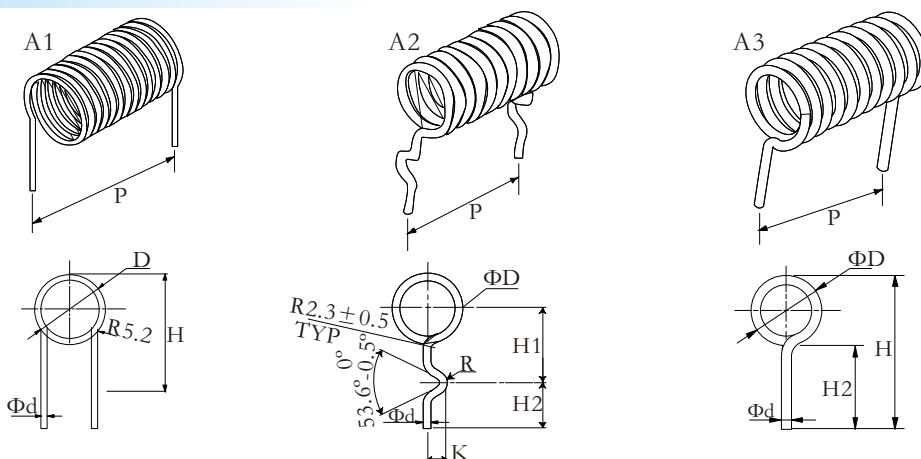

Type	Wire diameter (mm)	Rated Current(A)	Resistance Range	Operating Temperature	Remark
COA	0.8	4.5	5mΩ~500mΩ	-55°C~-180°C	Info needed: a.) Ohmic value b.) Rated current(amp) Optional: a.) Pitch b.) Lead wire diameter
	1.0	5.5	3mΩ~300mΩ		
	1.6	9.5	3mΩ~100mΩ		
	2.0	12	3mΩ~50mΩ		

● Ordering Information

Example:

COA	1	F	R01	C	A1
(1)	(2)	(3)	(4)	(5)	(6)
Series Name	Power Rating	Resistance Tolerance	Resistance Value	TCR	Forming

(1) Type: COA SERIES

(2) Power Rating: 05=0.5W、1=1W、2=2W

(3) Tolerance: F=±1%、G=±2%、H=±3%、J=±5%、K=±10%

(4) Resistance Value: R10=0.01Ω、R003=0.003Ω

(5) TCR: ±20ppm/°C

(6) Forming: A1 A2 A3

● Reference Standards

IEC 60115-1

Derating Curve

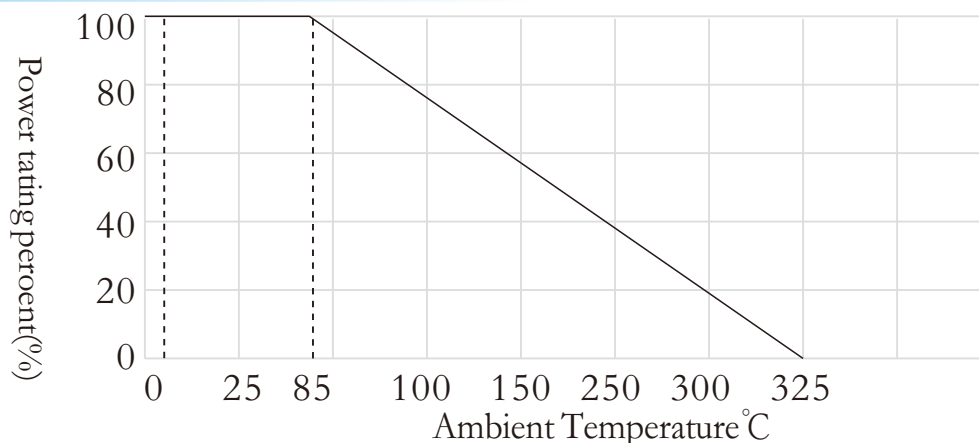

Performance Characteristics

Parameter / Performance Test & Test Method	Performance Requirements
Power Rating (Rated Ambient Temperature)	Full power dissipation at 85°C and linearly derated to zero at +325°C
Resistance Tolerance	±10%[K]; ±5%[J]; ±3%[H]; ±2%[G]; ±1%[F]
Temperature Range	-55°C to+325°C with suitable derating as per derating curve above
Voltage Rating / Limiting Voltage / Max. Working Voltage	$\sqrt{P \times R}$
Short time Overload (5 x Rated Power for 5 Secs.)	$\Delta R \pm [0.75 \% R_0 + R_{0005}]$ - Average $\Delta R \pm [1.25 \% R_0 + R_{0005}]$ - For resistance values near maximum range
Temperature Co-efficient of Resistance (Measured from -55°C to +125°C referenced to +30°C)	TCR To ± 20 ppm/°C [Depending on resistance value]
Damp Heat (Steady State) (40°C at 93 % R.H. for 1000 Hrs. – no load applied)	$\Delta R \pm [0.5 \% R_0 + R_{0005}]$ – Average
Endurance – Load Life [70°C with limiting voltage -1.5 hours on / 0.5 hours off for 1000 hours]	$\Delta R \pm [2.75 \% R_0 + R_{0005}]$ -Average
Resistance to Soldering heat - (260°C-270°C for 10 Secs)	$\Delta R \pm [0.2 \% R_0 + R_{0005}]$ -Typical
Solderability (As per IEC pub. 60068-2-20)	Must meet the requirements laid down