

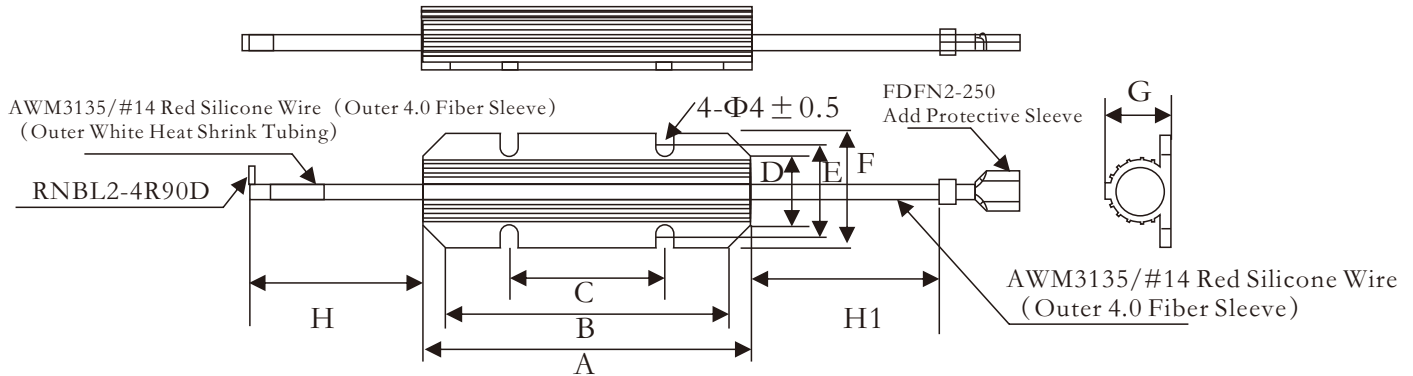

## ● Feature

- I Gold Aluminum shell surface, good performance in heat radiation, suitable for cooling plate installation, can be used in the atrocious environment.
- II Small volume, big power load, the instantaneous power load can reach more than 20 times.
- III Nickel-chromium alloy and high frequency porcelain core.
- IV Insulation resistance voltage up to 6 kv, 5000mΩ insulation resistance or greater, with super electrical safety features
- V Mechanical shock resistance performance is good, accord with GB/T20643.1-2006 electrical performance
- VI Widely used in new energy vehicles and photovoltaic inverter system.

## ● Dimensions



Type	Power (W)	Dimensions(mm)								
		A	B	C	D	E	F	G	H	H1
EVR	100W	± 1.0	± 1.0	± 0.5	± 0.5	± 0.5	± 1.0	± 0.5	± 10	± 10

## ● Power And Resistance etc

Type	Power (W)	Resistance Range(Ω)	Tolerance	Insulation voltage test (AC)	Dielectric With standing Voltage (DC)	Operating temperature
EVR	100	0.1Ω—51K	± 5% ± 10%	AC3000V/1Min Leakage current <5mA	DC1000/1Min insulation resistance ≥ 3000MΩ	-40℃ ~ +85℃

## ● Ordering Information

Example:

EVR	100	J	100R0
(1)	(2)	(3)	(4)
Series Name	Power Rating	Resistance Tolerance	Resistance

- (1) Type: EVR
- (2) Power Rating: 100=100W
- (3) Tolerance: J= ± 5%, K= ± 10%
- (4) Resistance Value: 10R0=10R、R10=0.1Ω、47R0=47Ω

## Derating curve

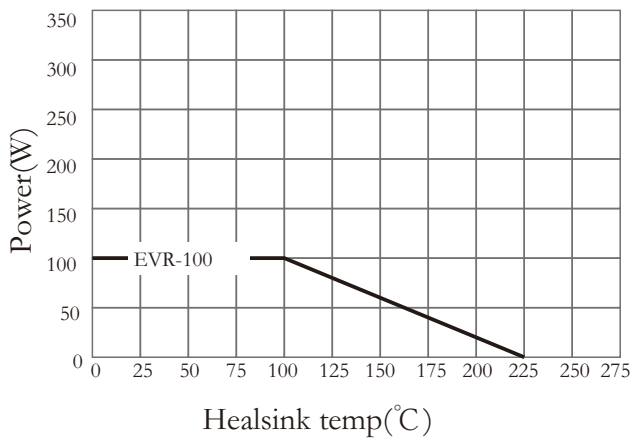

## Pulse energy

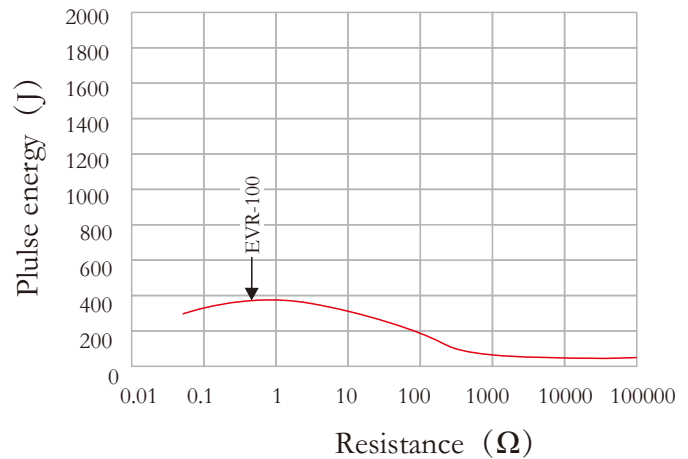

## Power overload

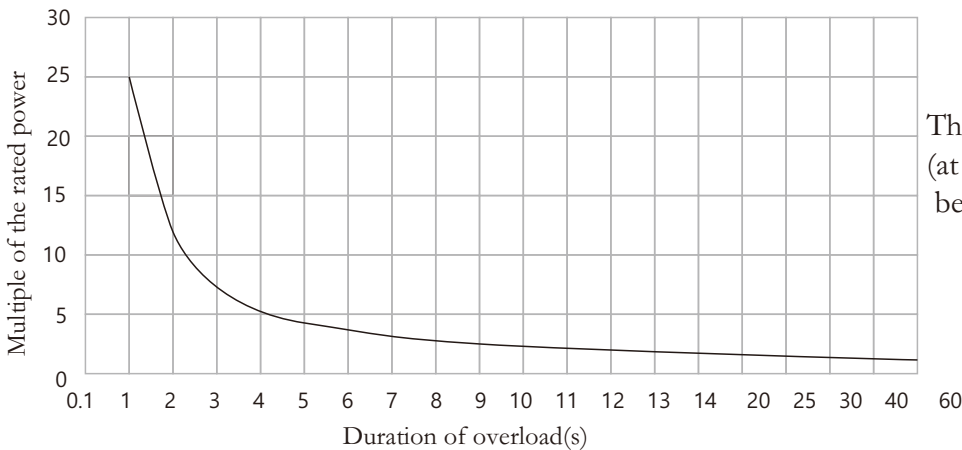

This graph indicates the amount that power (at 20°C) of the stand HS Series resistor may be reduced for overloads of 100 ms to 60 s.

## Surface temperature rise

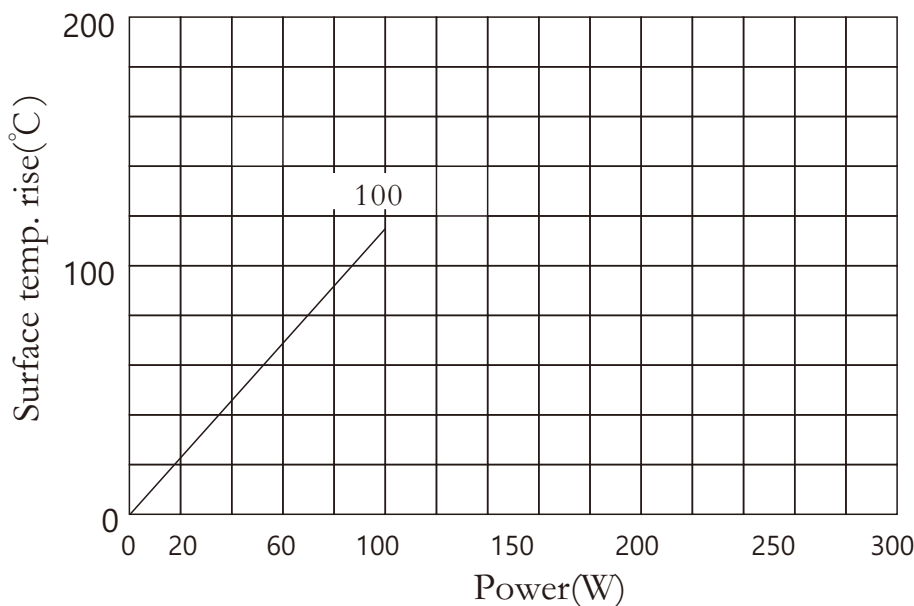

For resistor mounted on standard heatsink related to power dissipation.

Remarks: Heatsink is recommended as it got good heat radiation. Even you have used the heatsink, the maximum temperature 200°C can not be surpassed.

## ● Impact resistance principle

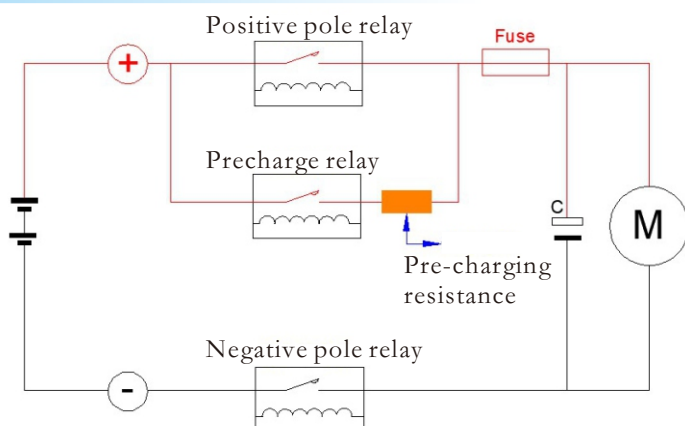

## ● Performance

Characteristics	SPEC	Test Methods															
Dielectric With standing Voltage (DC)	No spark, mechanical damage, arc and defective insulation, insulation resistance is more than 3000MΩ Min.	Resistance ontology is placed in a 90 ° V shape within the test fixture, put high pressure tester is one of the electrode on the ontology, other contact with the terminal lead, voltage, test time DC1000V 1 min.															
Insulation voltage test (AC).	The insulation voltage is greater than or equal to AC 3000V and the leakage current is less than 5mA. Above, cannot have the NG issue	Fix one end of the insulation test clip on the metal shell of the resistor and the other end on the wire at both ends of the resistor for testing setting time 60 seconds															
Resistance Temperature Coefficient (PPM/ °C)	≤ 10Ω at ± 250PPM ≥ 10Ω at ± 200PPM	$T. C. R = \frac{R2-R1}{R1 \times (T2-T1)} \times 10^{-6} PPM/°C$ R1: Resistance value at reference temp. (T1) R2: Resistance value at reference temp. (T2)															
Load Life	GB/T 2423.2 - Bb	Permanent resistance change after 168 hours operating at rated continuous working voltage with a duty cycle of 1.5 hours on 0.5 hours off at 70 ± 5°C for 84 cycles.															
Temperature Cycling	Δ R/R at ± 5% No obvious mechanical damage	Resistance change after continuous 5 cycles for duty cycle as specified below. <table border="1" style="margin-left: 20px;"> <thead> <tr> <th>Step</th> <th>Temperature</th> <th>Time</th> </tr> </thead> <tbody> <tr> <td>1</td> <td>-55°C</td> <td>30 Minutes</td> </tr> <tr> <td>2</td> <td>+25°C</td> <td>10 ~ 15 Minutes</td> </tr> <tr> <td>3</td> <td>+85°C</td> <td>30 Minutes</td> </tr> <tr> <td>4</td> <td>+25°C</td> <td>10 ~ 15 Minutes</td> </tr> </tbody> </table>	Step	Temperature	Time	1	-55°C	30 Minutes	2	+25°C	10 ~ 15 Minutes	3	+85°C	30 Minutes	4	+25°C	10 ~ 15 Minutes
Step	Temperature	Time															
1	-55°C	30 Minutes															
2	+25°C	10 ~ 15 Minutes															
3	+85°C	30 Minutes															
4	+25°C	10 ~ 15 Minutes															
Short Time Overload	ΔR/R Nomal size at ± 3% With no evidence of arcing burning, or charring	10 times the rated output voltage, time to 5 seconds, after cooling at room temperature measuring the resistance change value. Voltage calculation formula. $E = \sqrt{2.5 \times P \times R}$															
Simulate precharge tes	According to the precharge resistance maximum use (DC) voltage, charging 1S discharge 2S, continuous impact 30,000 times, EVR resistance cannot be opened, the change rate is less than or less than 5%	Applying high power DC voltage, RC prefi lled resistance in serie Y s capacitor anode, charging circuit, bypass resistance discharge, blunt electricity 10000 consecutive complete EVR resistance after turn off the power supply, check the resistance value shall have no resistance, open surface without damage phenomenon, the resistor test before and after test the resistance rate of 5% or less															
Vibration experiment	ΔR/R/at ± 2% surface without damage IEC60068-2-6FC	Set the vibrator frequency of 0.75mm 10~500HZ, and end acceleration of 98m/s X.Y.Z. axis for 2 hours, a total of 6 hours. Confirm that the change rate of product resistance value is ≤ 3%, and there is no unwelding phenomenon in winding															
Vibration experiment	According to GB/T2423.17 test cycle 48H, customer special requirements in accordance with customer standards	A certain proportion of brine solution (95%) was prepared. The laboratory temperature was 35°C, and the saturated air bucket temperature was 47°C. Decision criteria: the RP = 10 can be directly through the RP = 7~9 test result, if there is no special request, can give in to receive the RP = 3~6 test result, need to evaluate relevant functional departments, and then according to the result of evaluation to judge the RP = 0 ~ 2 test result, for not qualified															