

High Voltage Resistors HVT Series combine proprietary non-inductive resistance system and design to achieve low temperature coefficient, low voltage coefficients, high stability and increased high operating voltages.

Precision High Voltage Resistors HVT Series are designed to meet the demanding requirements of TWT power supplies, electron microscopes, X-ray systems, high resolution CRT displays and geophysical instruments.

## ● Dimensions

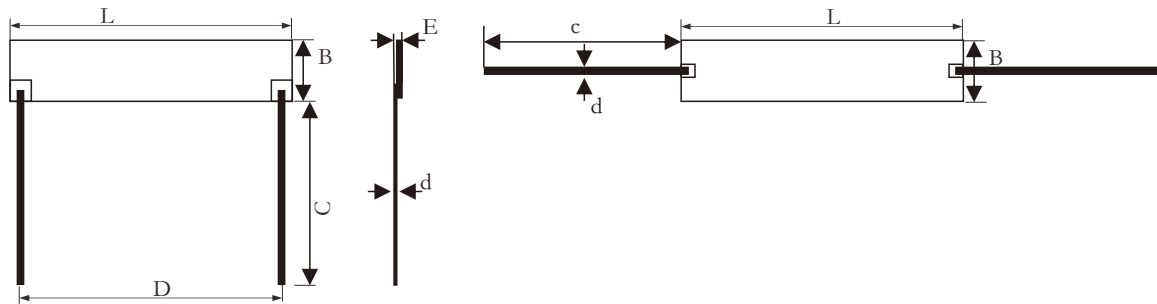

| Type  | Power(w) | Max Continuous Oper. Voltage(KV) | Dimensions(mm) |         |         |         |       |          |
|-------|----------|----------------------------------|----------------|---------|---------|---------|-------|----------|
|       |          |                                  | L ± 0.5        | B ± 0.5 | C ± 0.5 | D ± 0.5 | E max | D ± 0.05 |
| HVT01 | 1.0      | 5                                | 12.7           | 5.08    | 10      | 10.16   | 2.0   | 0.5      |
| HVT02 | 2.5      | 11                               | 24.9           | 7.05    | 35      | 20.5    | 2.5   | 0.5      |
| HVT03 | 3.3      | 20                               | 38.1           | 12.7    | 35      | 35.56   | 2.5   | 0.5      |
| HVT04 | 4.5      | 30                               | 50.80          | 15.24   | 35      | 48.26   | 2.5   | 0.8      |
| HVT06 | 6.5      | 45                               | 76.2           | 15.24   | 35      | 73.66   | 3.0   | 0.8      |
| HVT09 | 9.0      | 60                               | 101.6          | 15.24   | 35      | 99.06   | 3.0   | 0.8      |

## ● Power And Resistance etc

| Type  | Power(w) | Resistance Range    | VCR (-ppm/V)     |
|-------|----------|---------------------|------------------|
| HVT01 | 1.0      | 1K-250M<br>250M-3G  | < 2.00<br>< 3.70 |
| HVT02 | 2.5      | 1K-500M<br>500M-7G  | < 1.00<br>< 1.20 |
| HVT03 | 3.3      | 1K-1G<br>1G-10G     | < 1.00<br>< 1.20 |
| HVT04 | 4.5      | 1K-1G<br>1G-20G     | < 1.00<br>< 1.10 |
| HVT06 | 6.5      | 1K-1.5G<br>1.5G-30G | < 1.00<br>< 1.10 |
| HVT09 | 9.0      | 1K-2G<br>2G-40G     | < 0.90<br>< 0.60 |

## ● Reference Standards

JISC 5201-1

## ● Ordering Information

Example:

|                           |                           |                                  |                         |                            |
|---------------------------|---------------------------|----------------------------------|-------------------------|----------------------------|
| HVT<br>(1)<br>Series Name | 03<br>(2)<br>Power Rating | J<br>(3)<br>Resistance Tolerance | 50<br>(4)<br>Resistance | C3<br>(5)<br>T.C.R(PPM/°C) |
|---------------------------|---------------------------|----------------------------------|-------------------------|----------------------------|

(1)Type: HVT SERIES

(2)Power Rating: 01=1W,02=2.5W,03=3.3W,04=4.5W,06=6.5W,09=9W

(3)Tolerance: B= ± 0.1%,C= ± 0.25%,D ± 0.5%F= ± 1%,G= ± 2%,J= ± 5%,K= ± 10%

(4)Resistance:1KR00=1KΩ, 2GR00=2GΩ

(5)T.C.R:C3=25PPM/°C ,C5=50PPM/°C

## ● Derating Curve

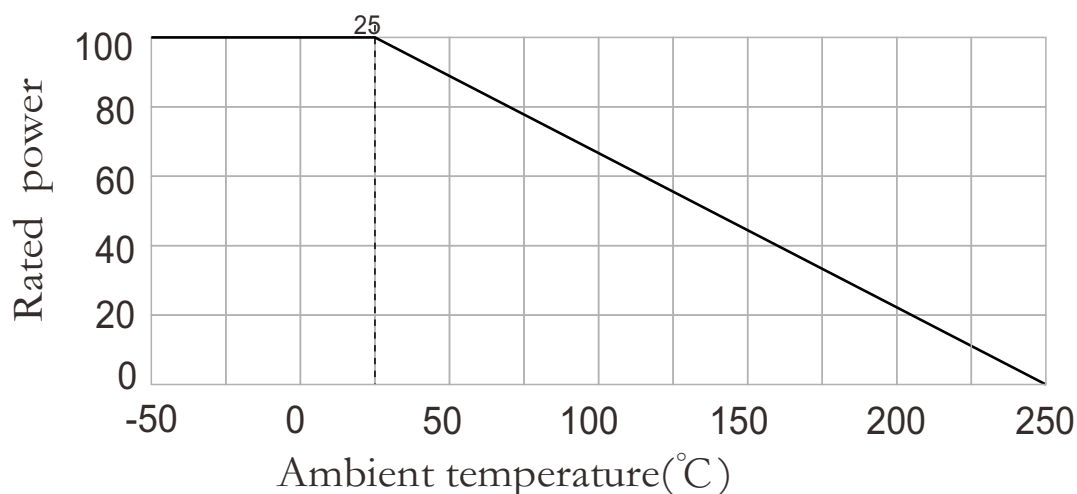

## ● Performance

| Test Items               | Test Methods(JIS C 5201-1)                                      |  |
|--------------------------|---|--|
| Resistance Values        | from 1K0 to 10G, 1W and 2.5W; to 100G on other P/N              |  |
| Tolerances               | 0.1%, 0.25%, 0.5%, 1%, 2%, 5%, 10%                              |  |
| Temperature Coefficients | 15, 25, 50 and 100 ppm/°C (50 ppm/°C to 100G, other on request) |  |
| Operating Temperature    | -55.. +250C   | (extended temperature range to 350° C available) |
| Insulation Resistance    | > 10'000 MΩ   | 25 ° C 75% relative humidity                     |
| Dielectric Strength      | > 1'000 Volt  | 25 ° C 75% relative humidity                     |
| Thermal Shock            | ΔR/R < 0.1% typ., 0.20% max.                                    | MIL Std. 202, method 107 Cond.C   IEC 68-2-14    |
| Overload                 | ΔR/R < 0.1% typ, 0.25% max.                                     | 1,5 x Pnom, 5 sec (do not exceed max. voltage)   |
| Moisture Resistance      | ΔR/R < 0.1% typ, 0.25% max.                                     | MIL Std. 202, method 106   IEC 68-2-3            |
| Load Life                | ΔR/R < 0.1% typ., 0.25% max.                                    | 1000 hours at rated power   IEC115-1             |